

Broil King®

Broil King®
495055
495055UK
495055CH
495055EU
495055GBC



Broil King®
496055
496055UK
496055CH
496055EU
496055GBC





HARDWARE INCLUDED



Y-12859S		X16	G01CH038		X2
Y-12865S		X12	Y-11560S		X2
49302-26		X1	Y-11698S		X2
63599-73		X2	S21061		X2
Y-29304S		X4	C03010		X2



TOOLS REQUIRED



#3 PHILLIPS

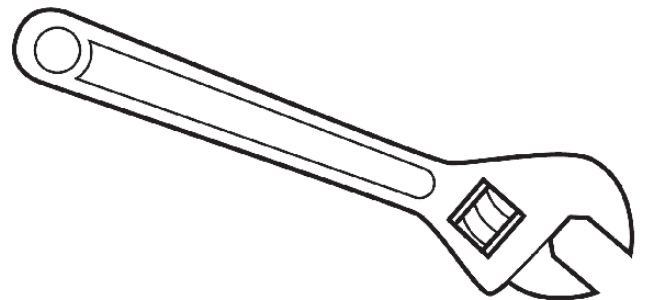
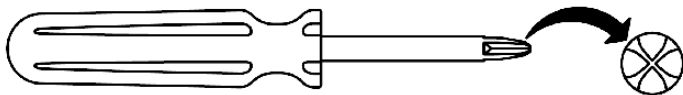

1

(12)

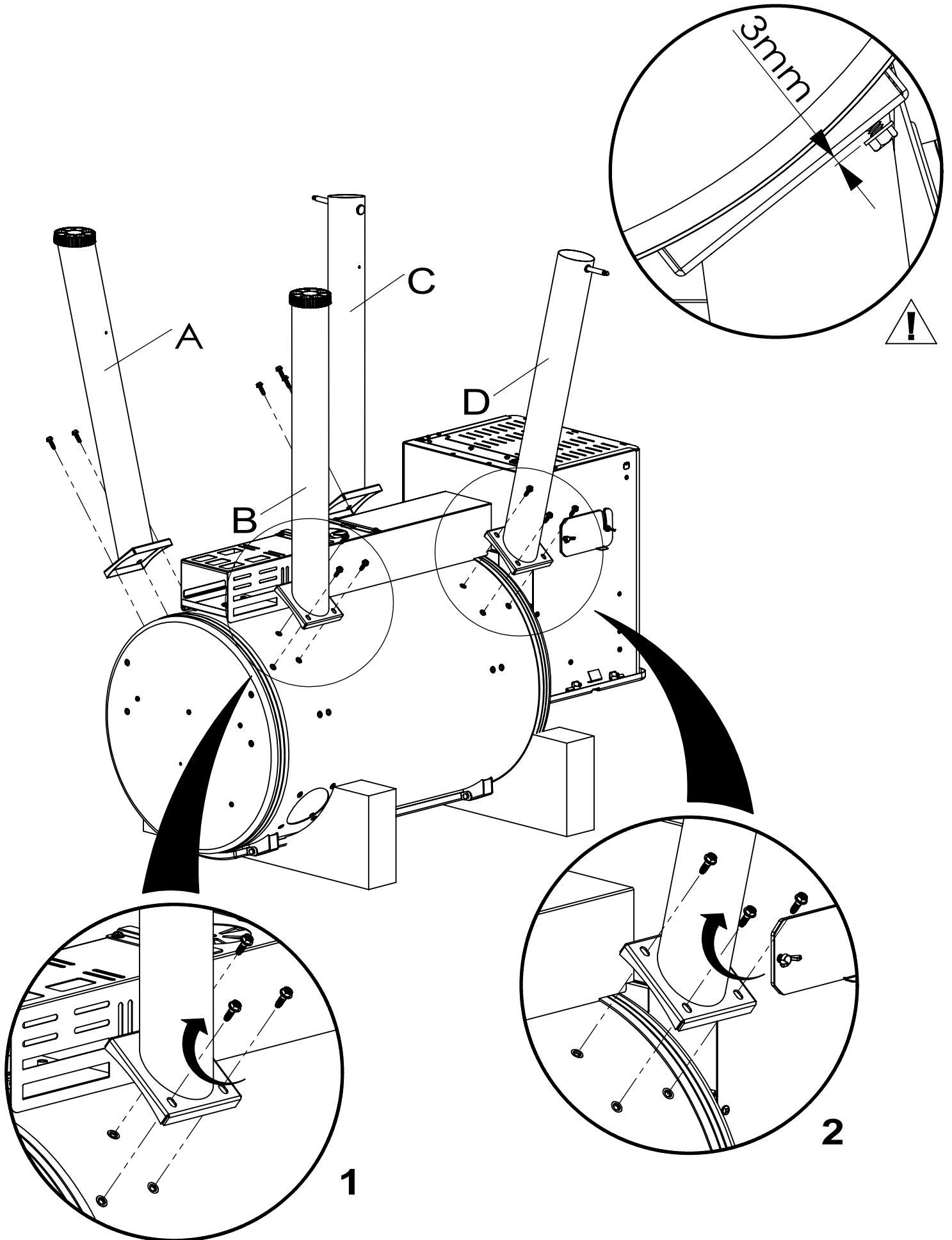
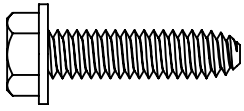

2

(4)

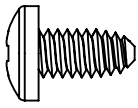

(2)

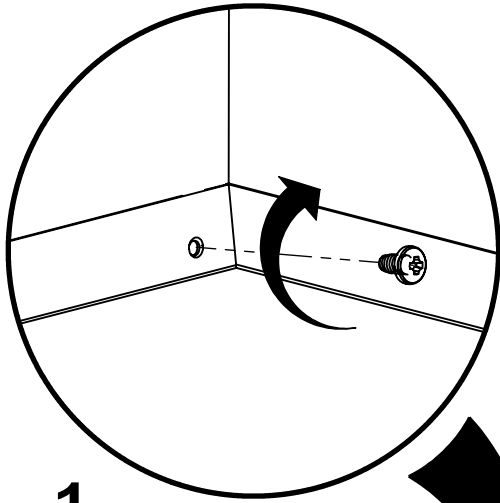
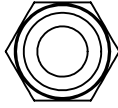

1

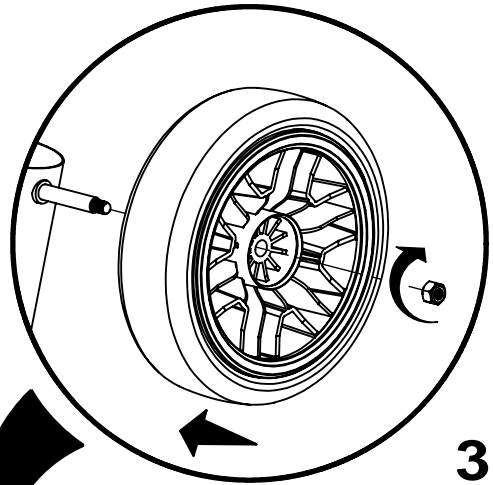

3

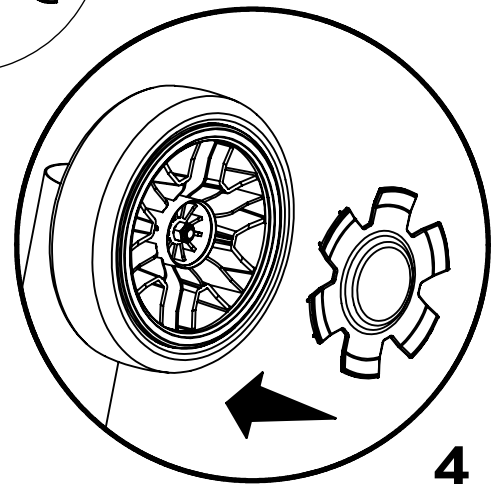
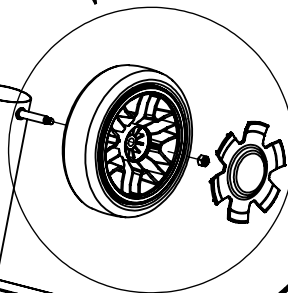
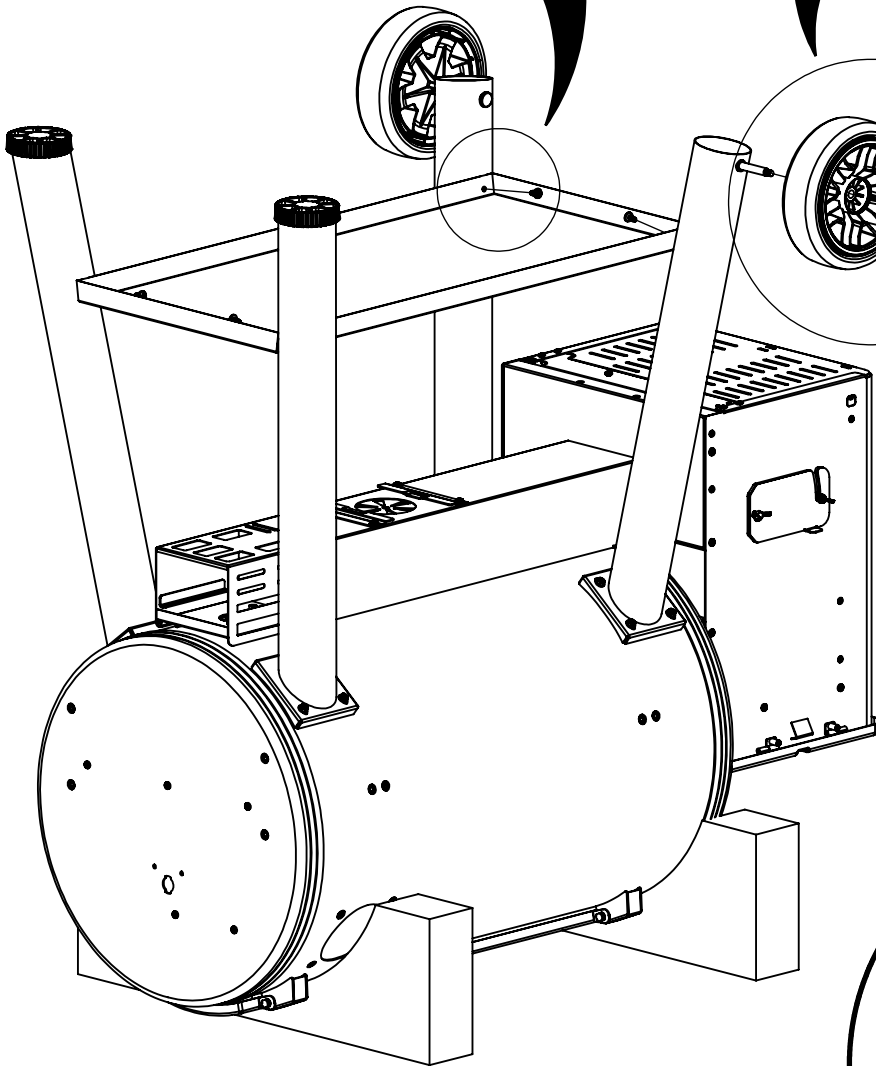

4

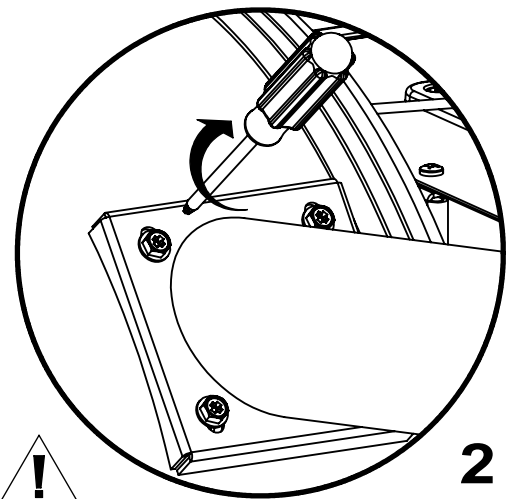

2

3

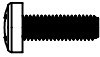
(2) 

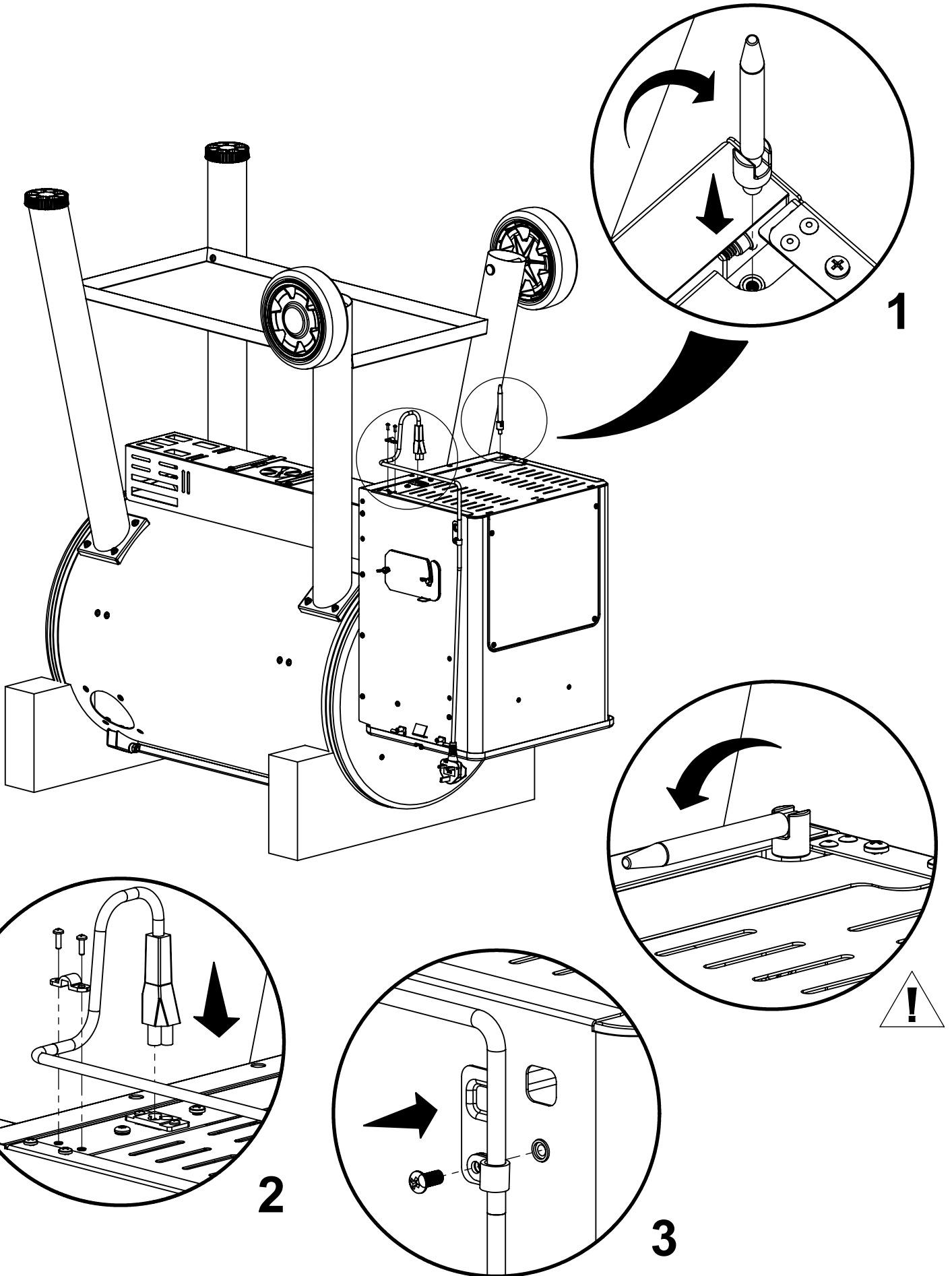

1

2

3

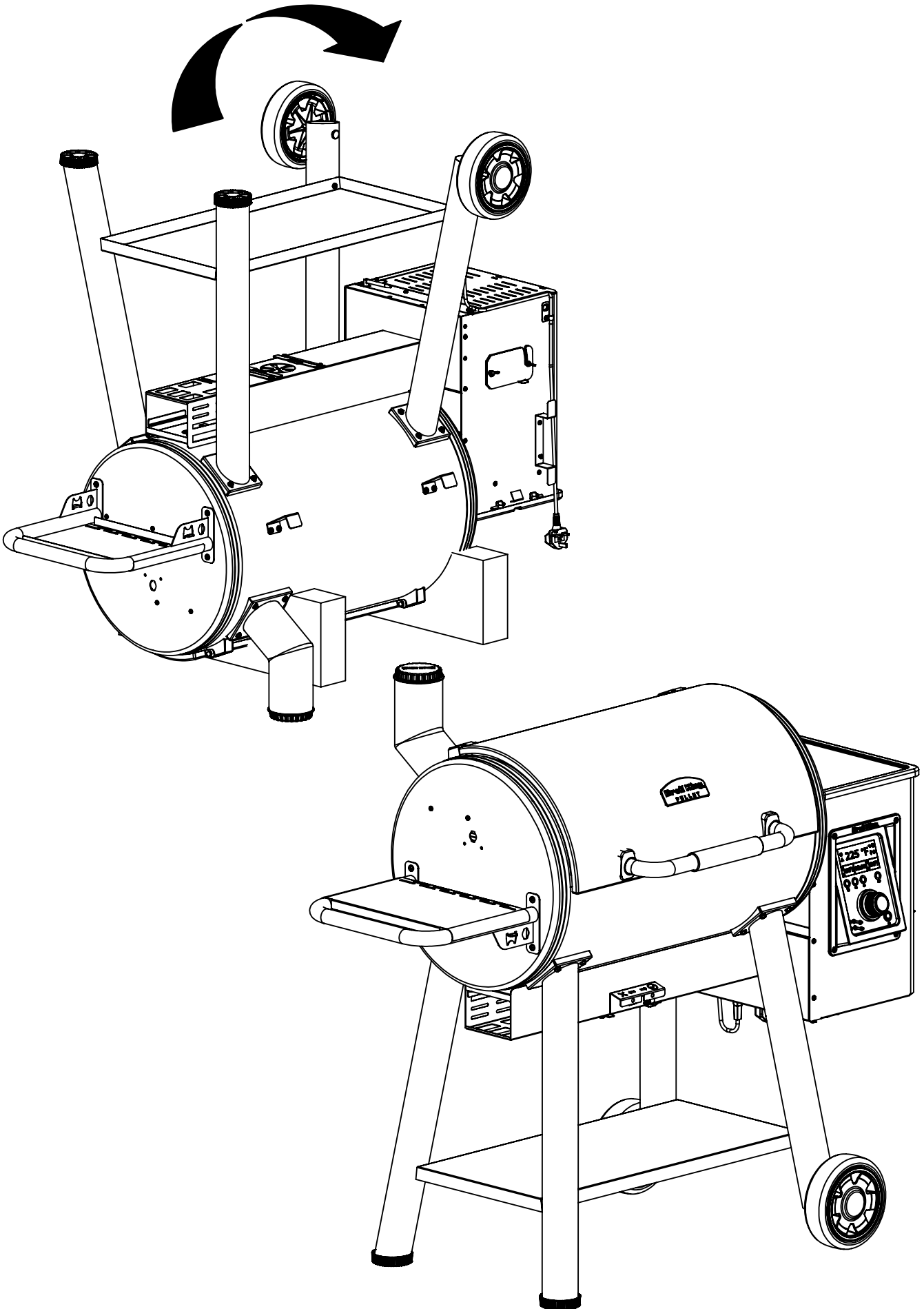

5

(2)

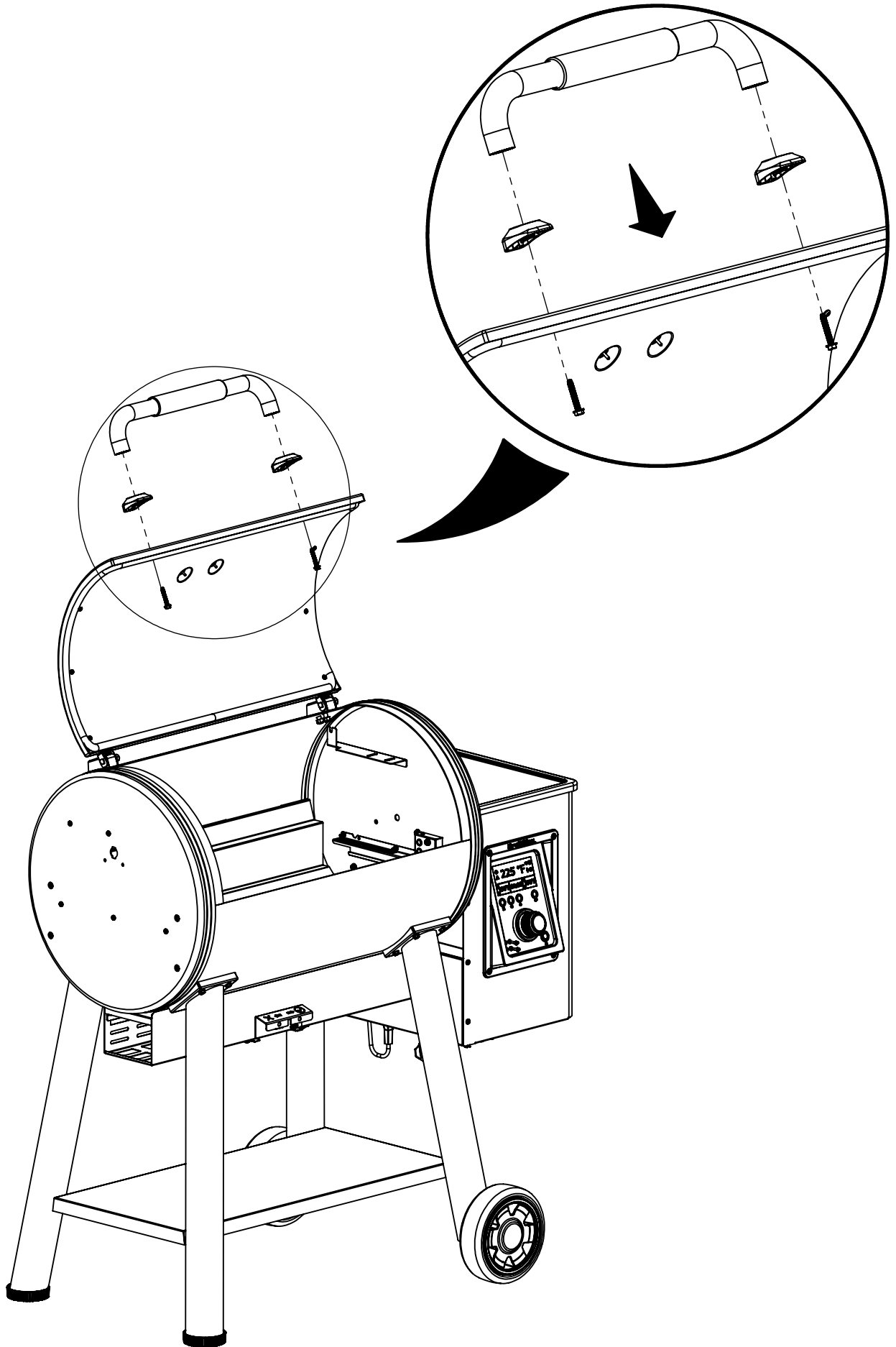
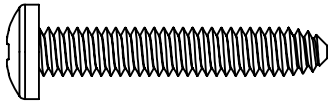

6

(4)

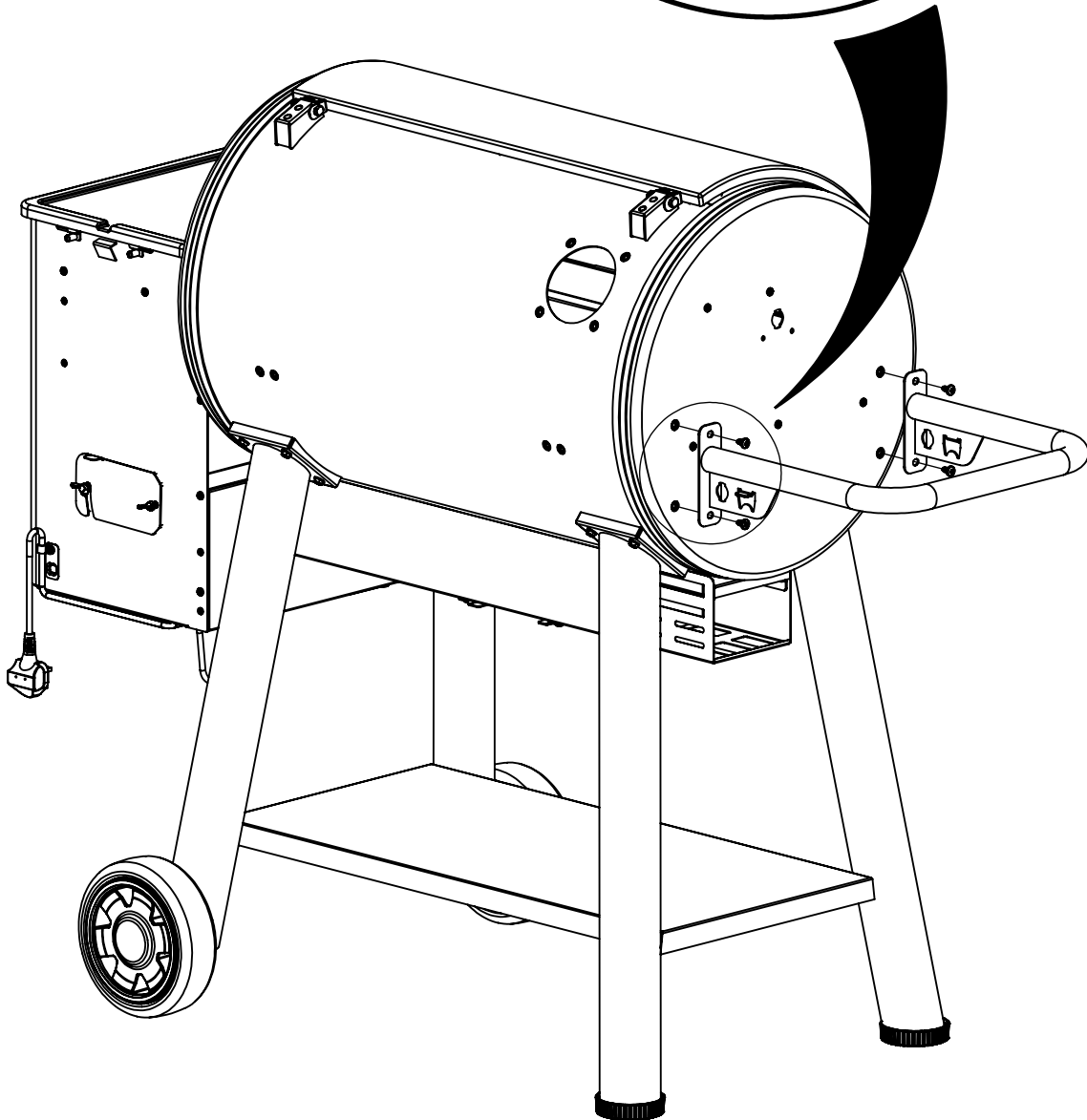
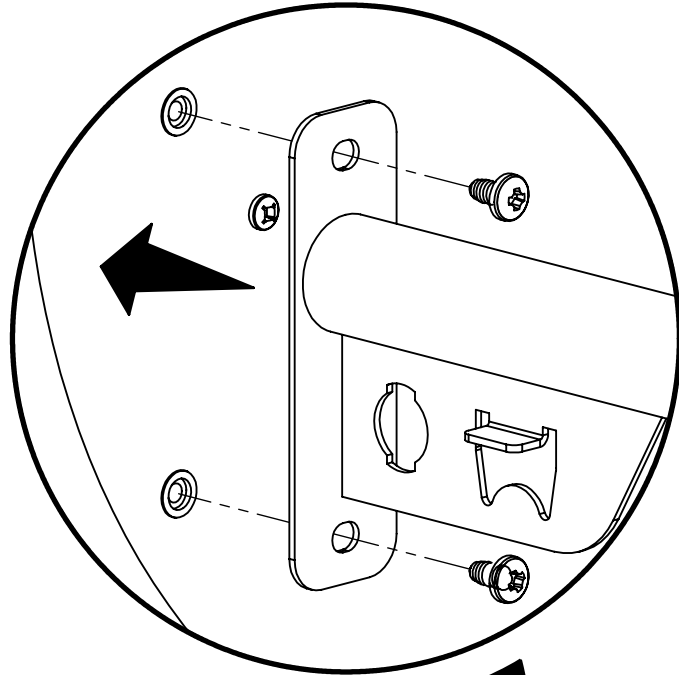
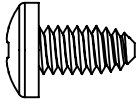

7

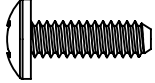
(2)  (1)

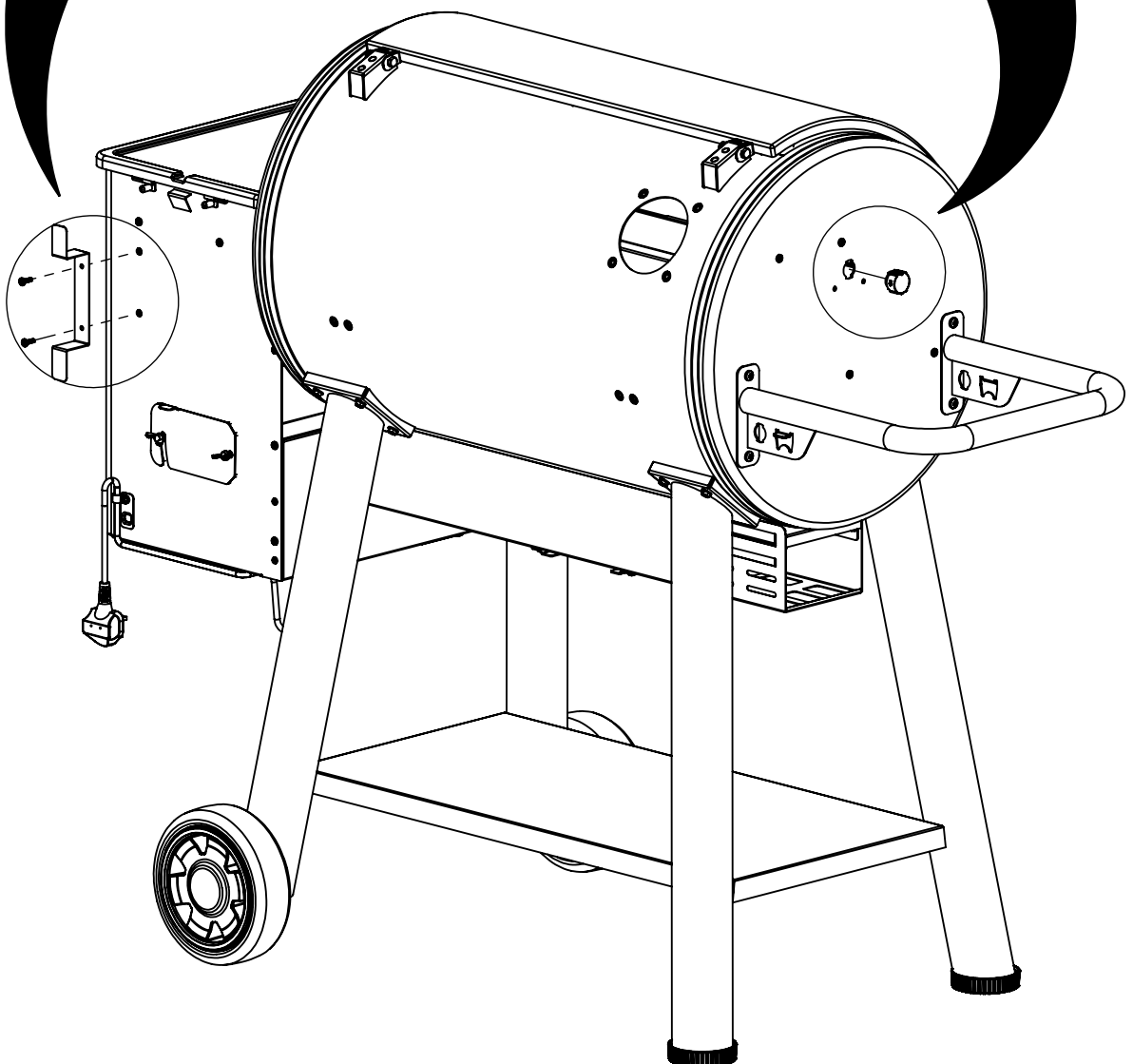
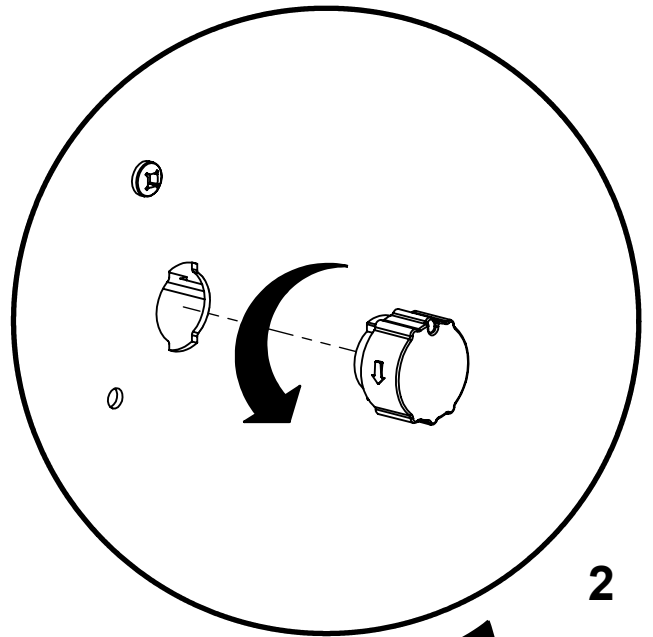
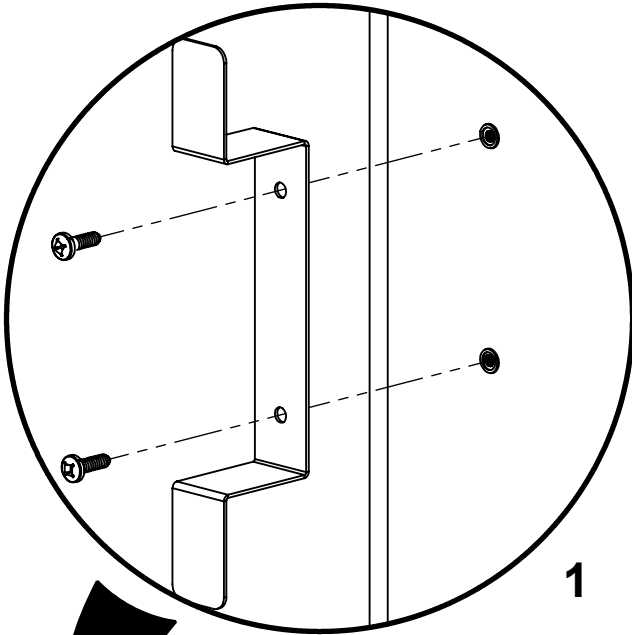
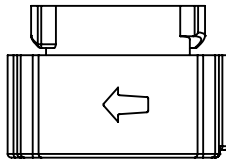

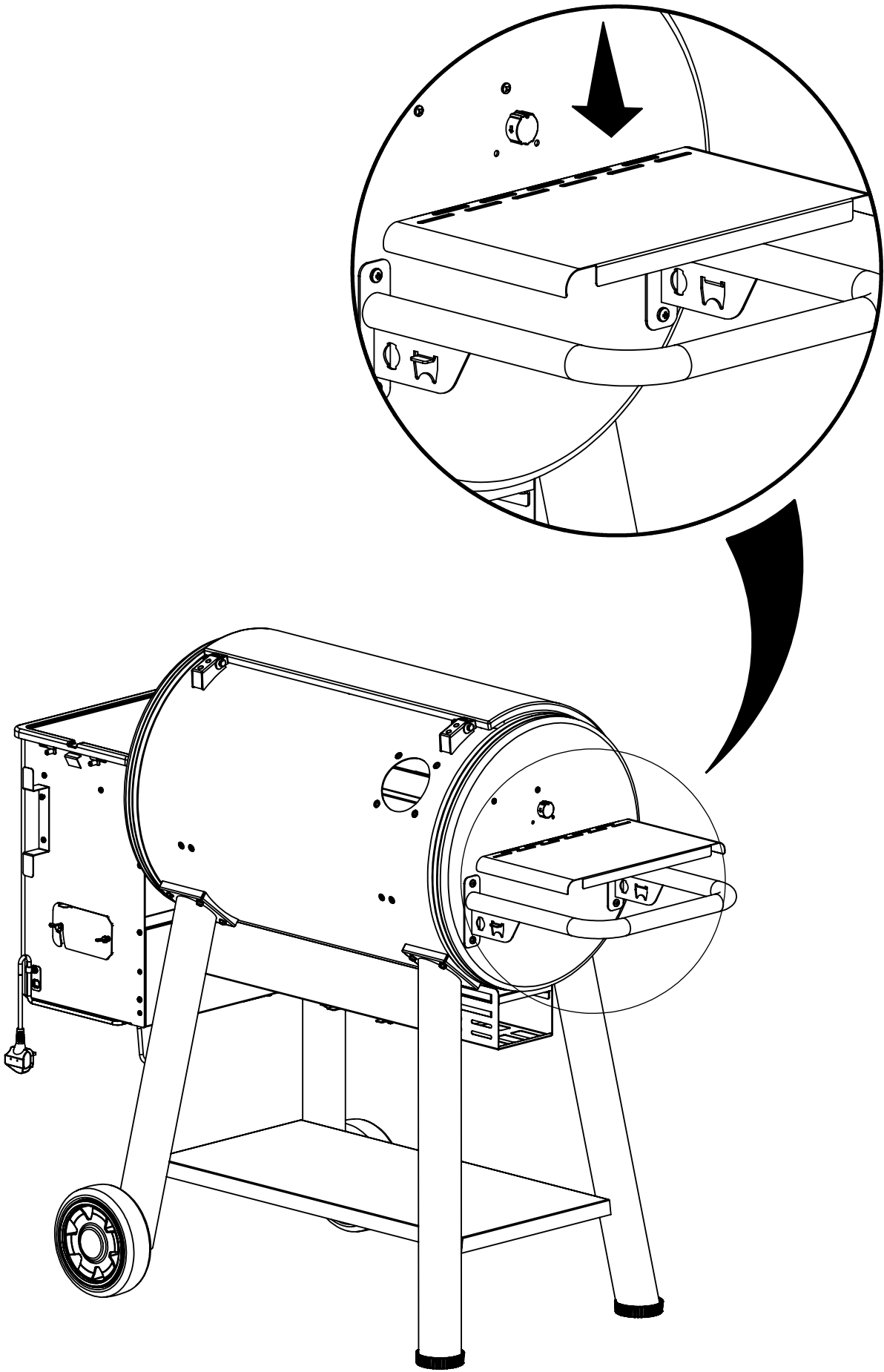

9

(4)

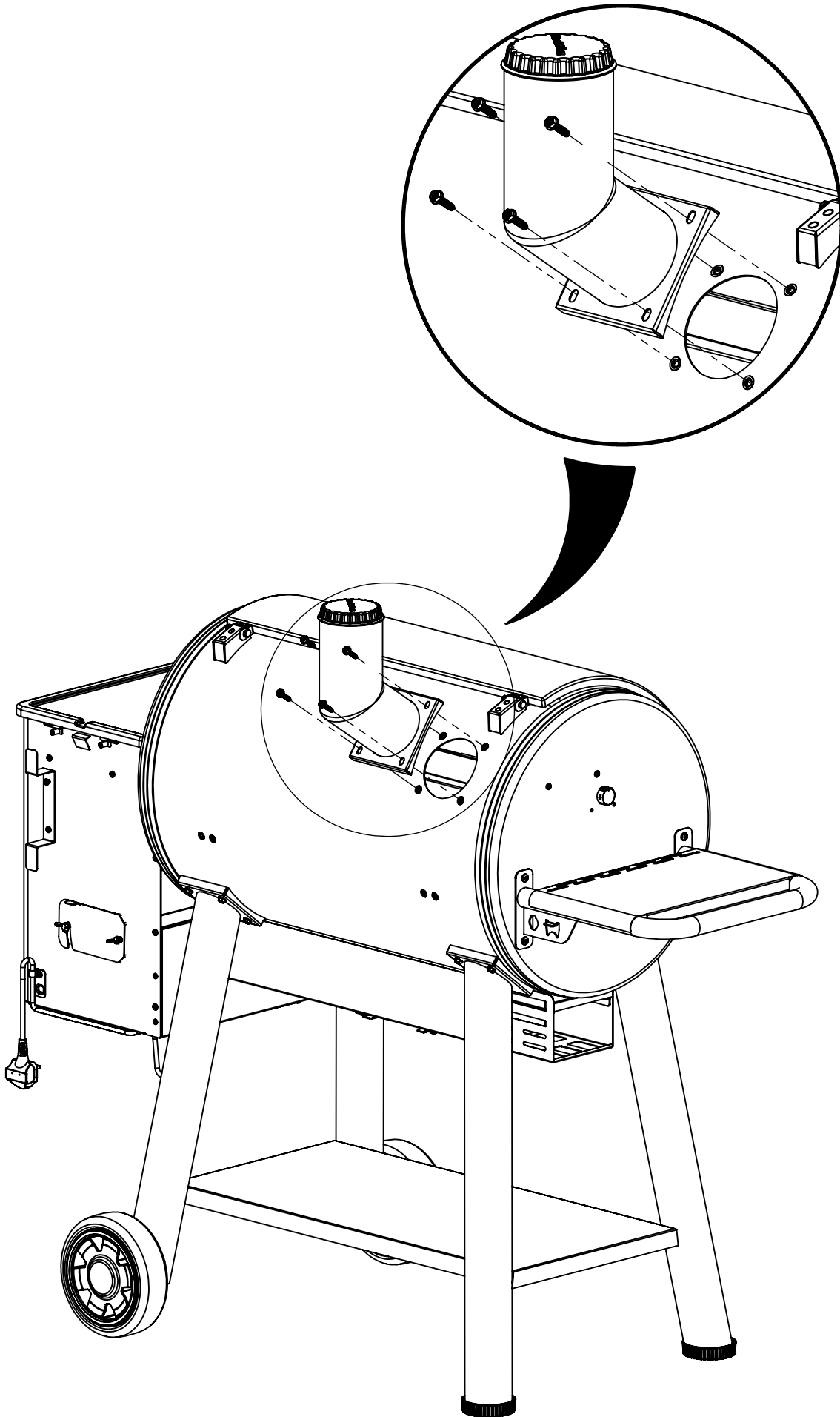
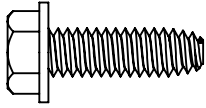

10

(4)

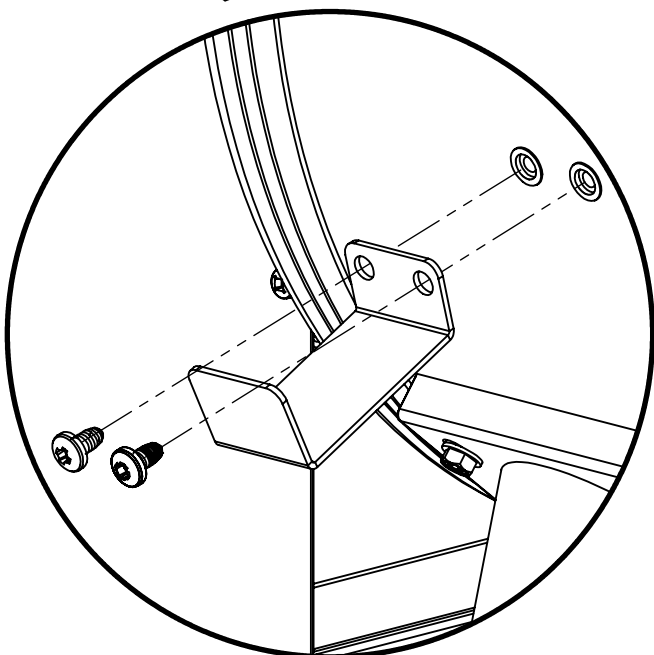
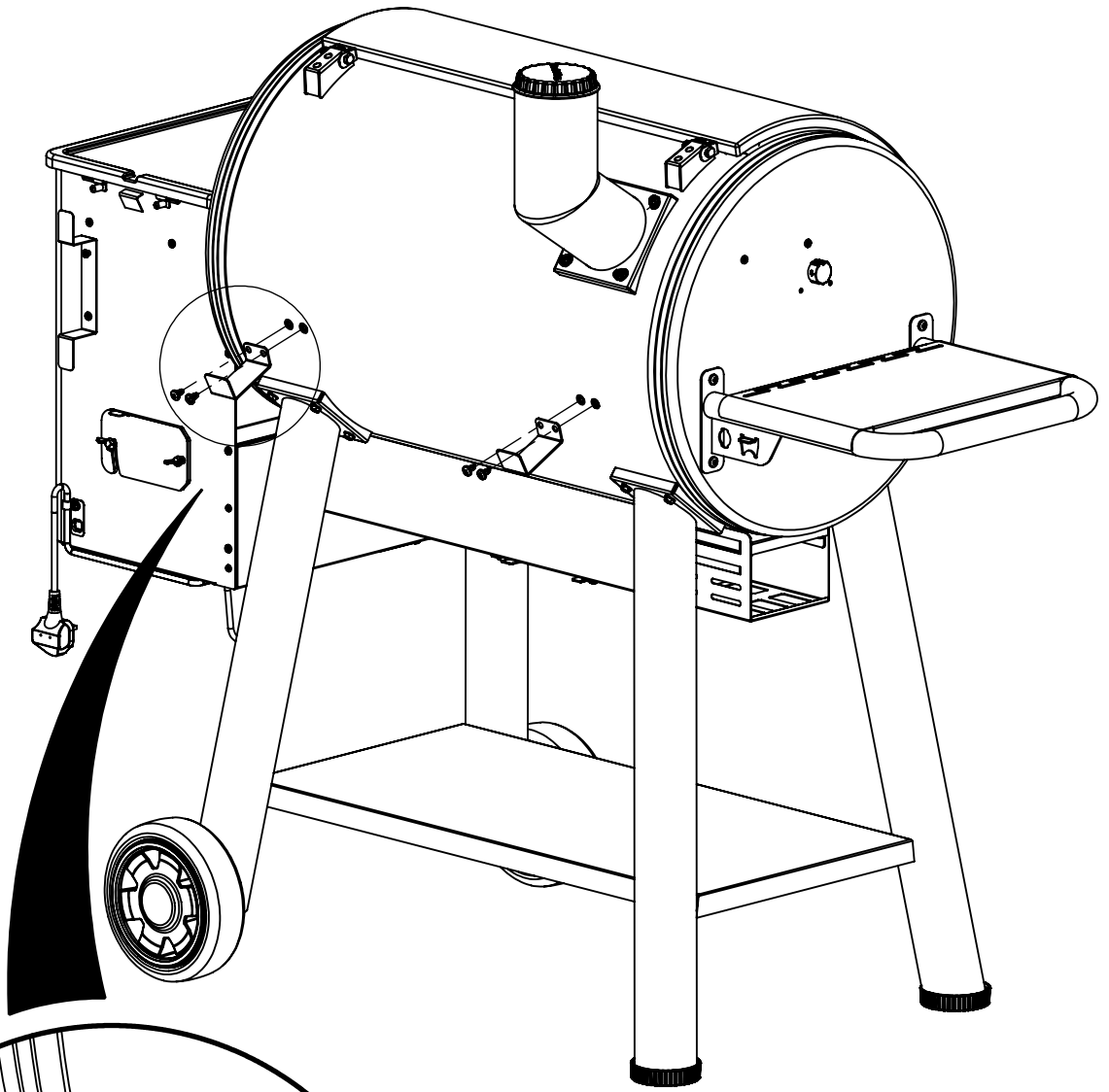
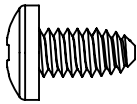

11

(2)

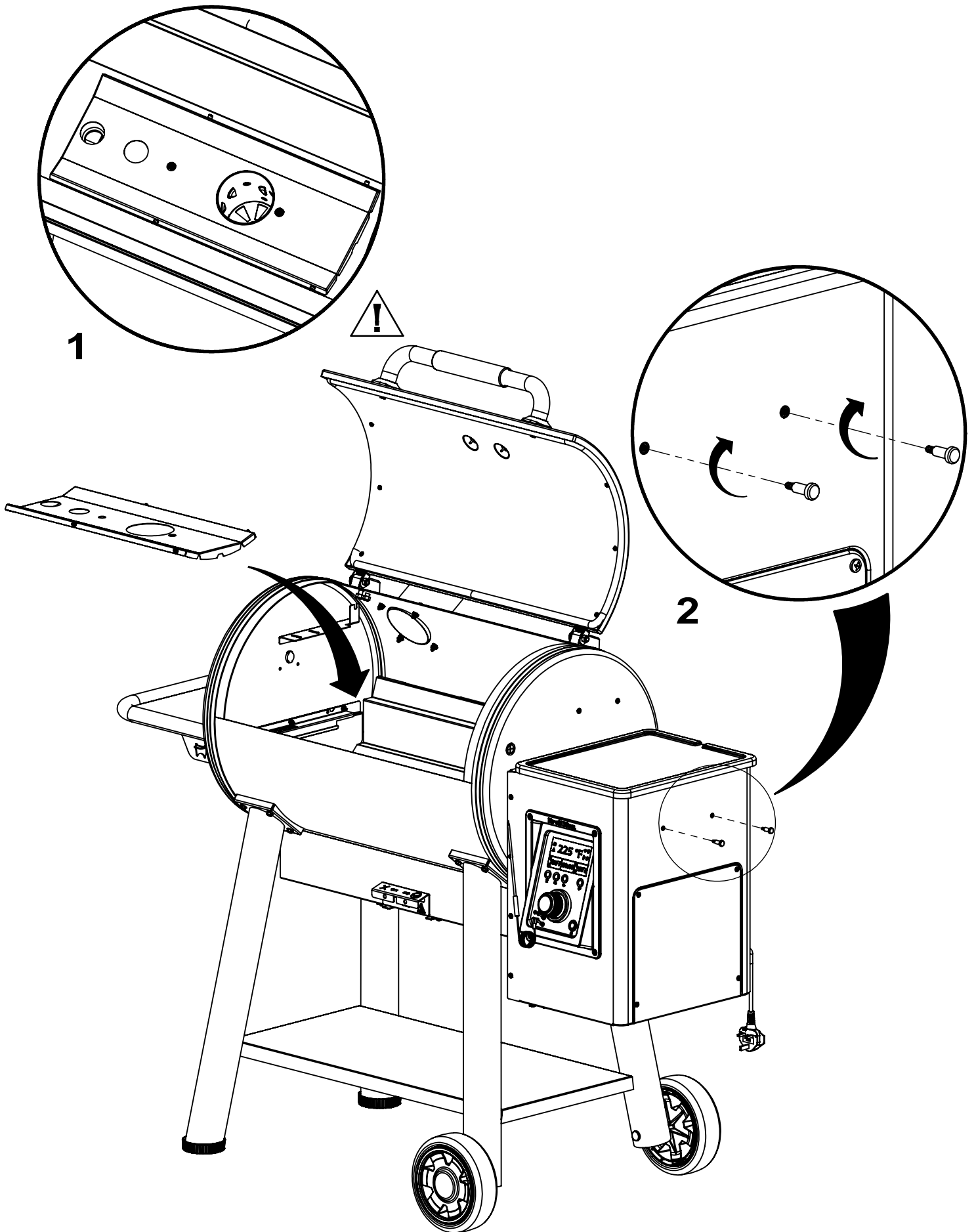
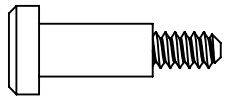

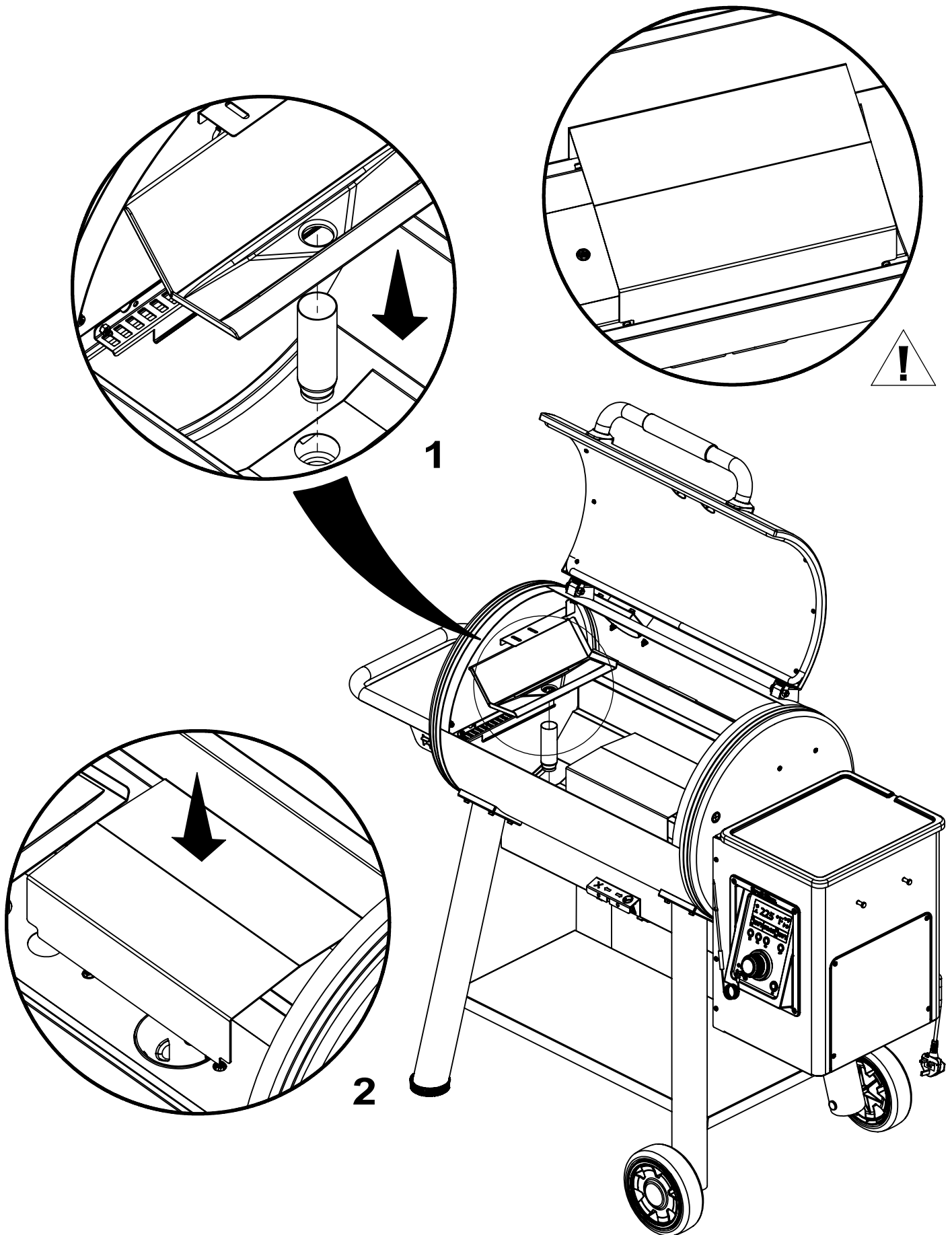

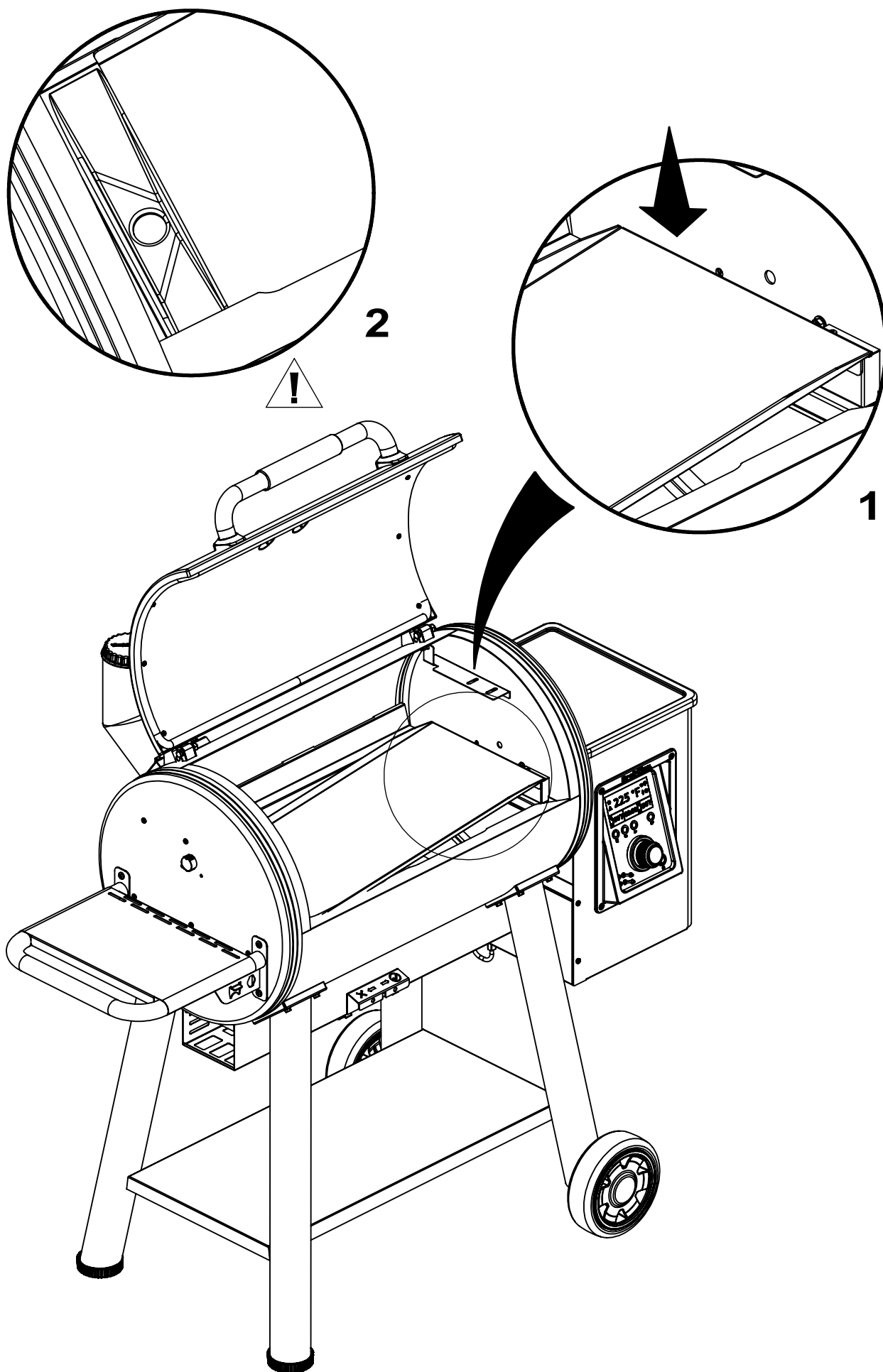

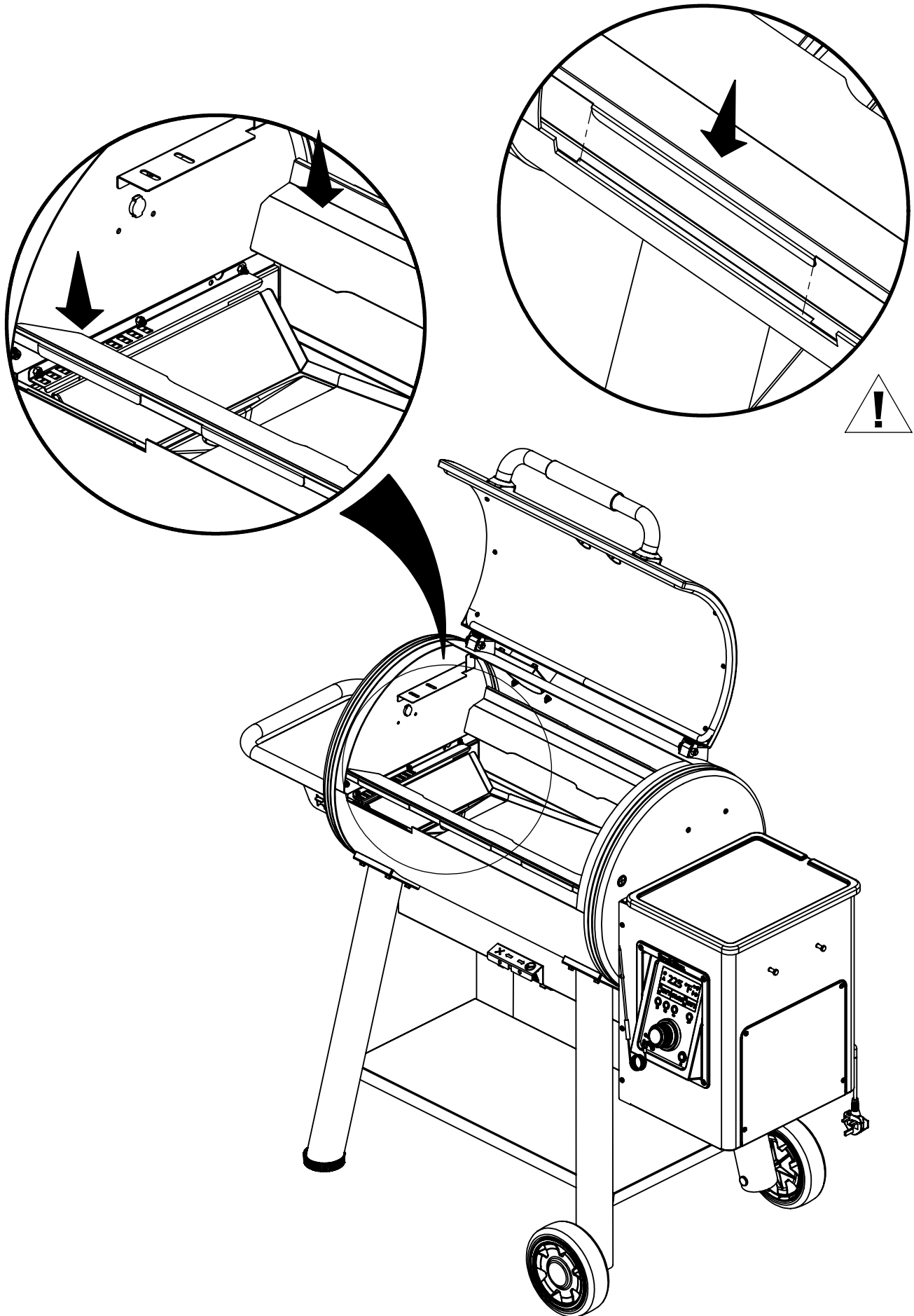

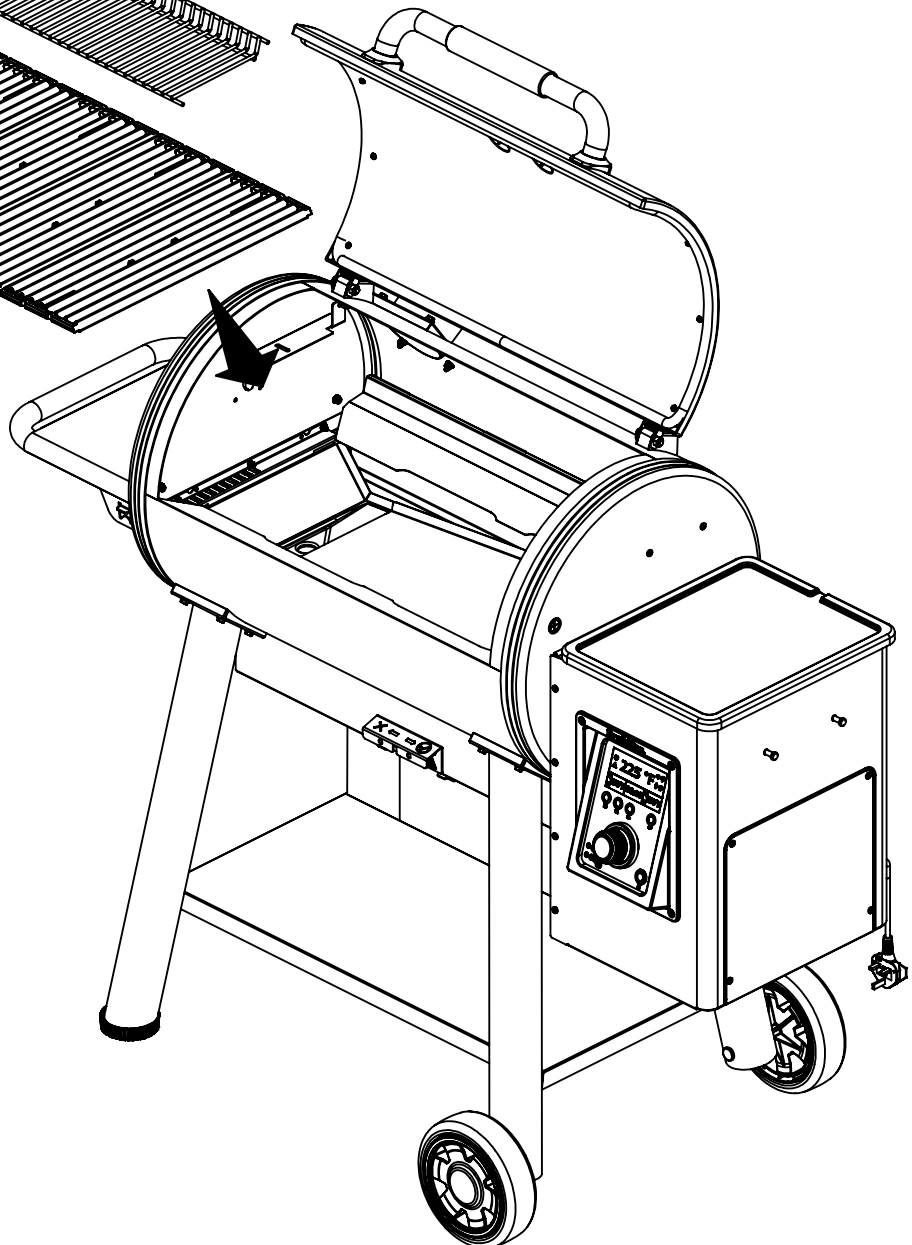
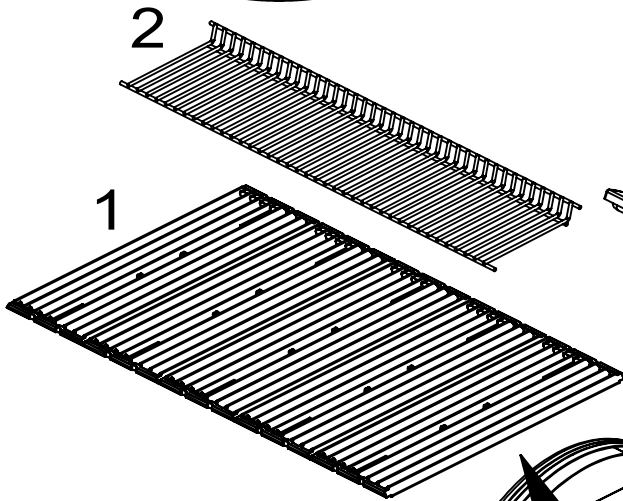
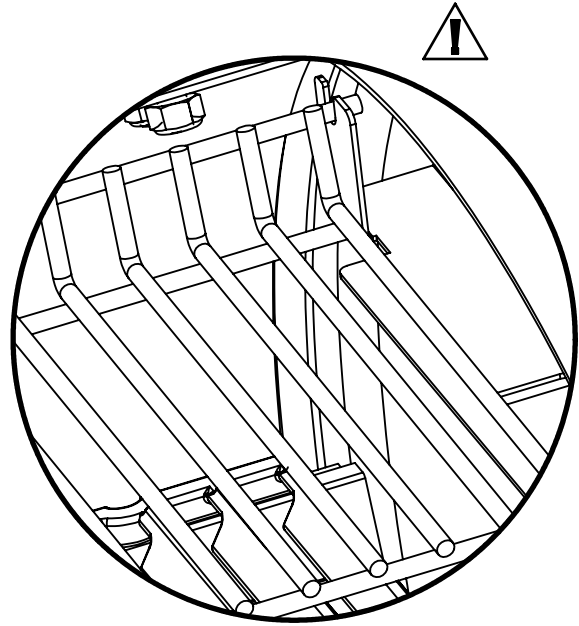
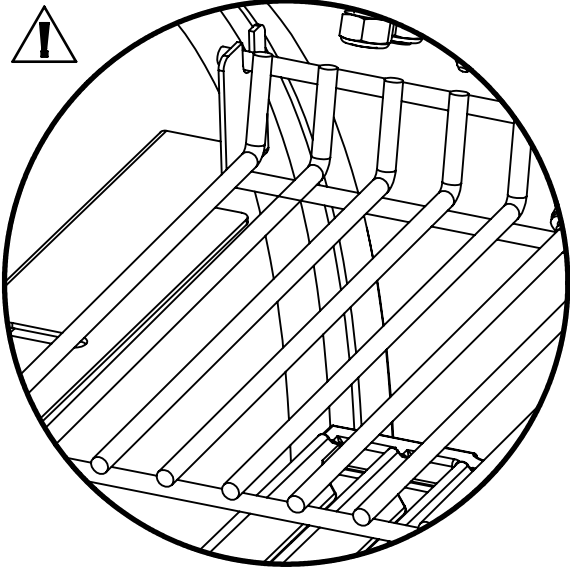

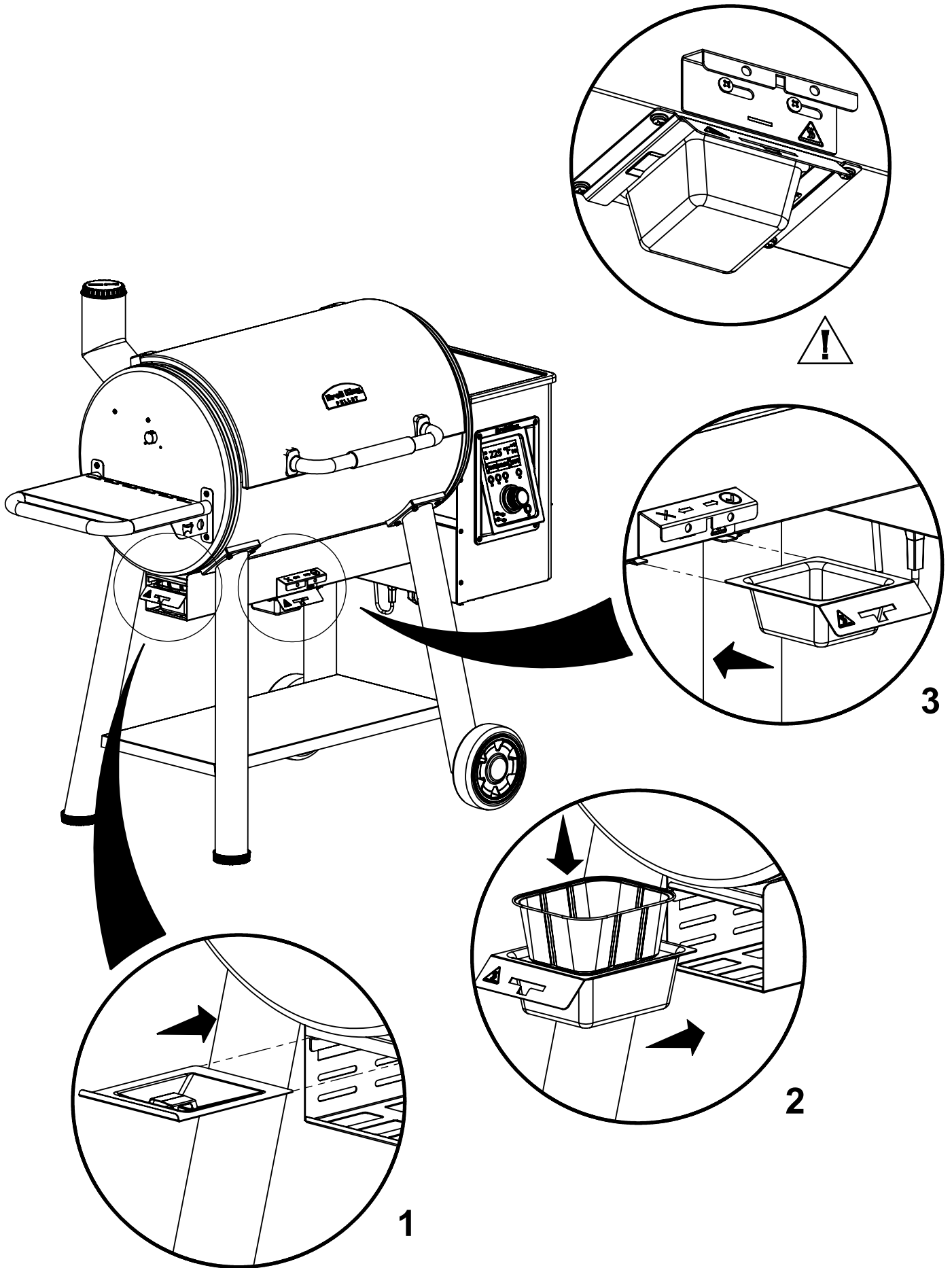

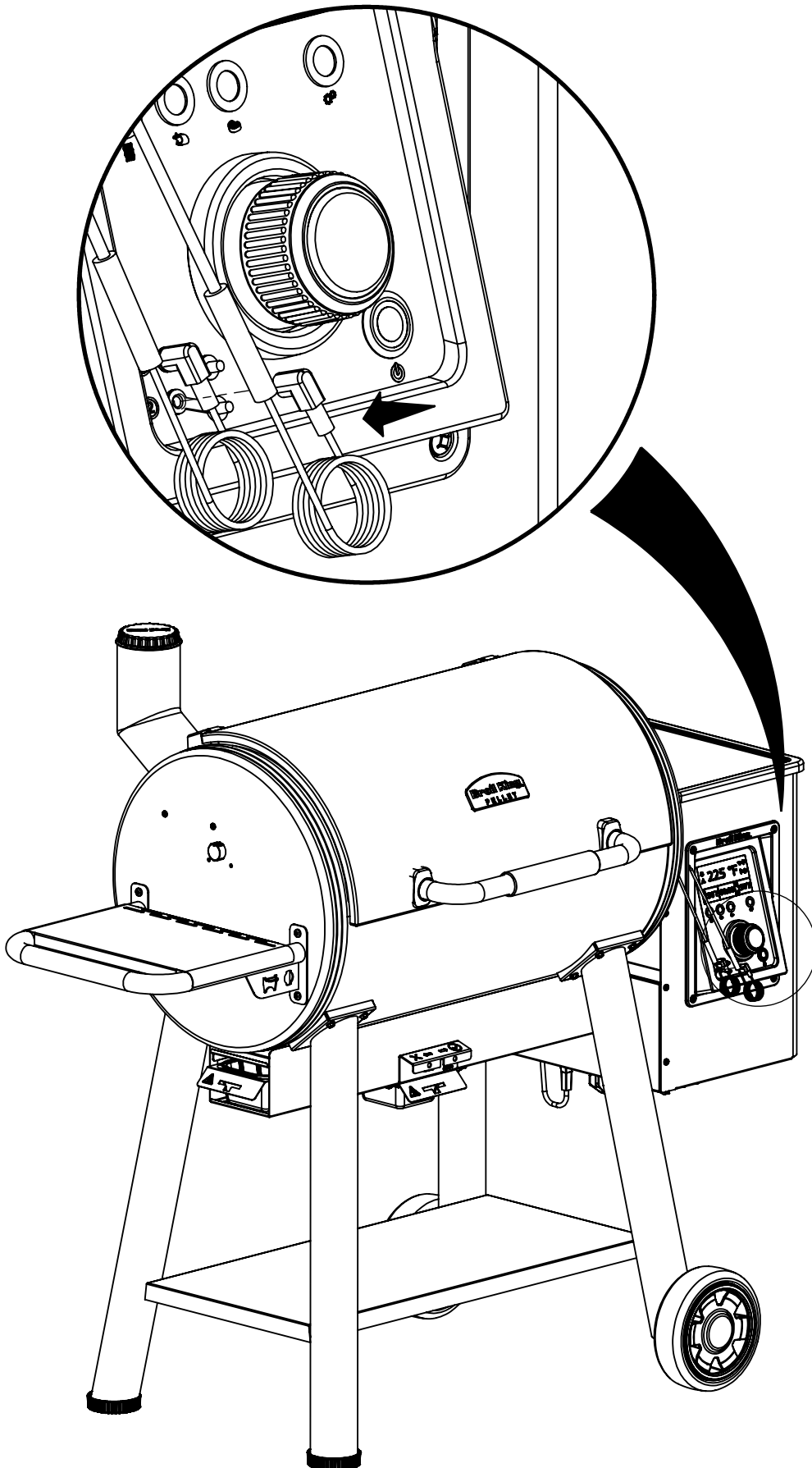

18

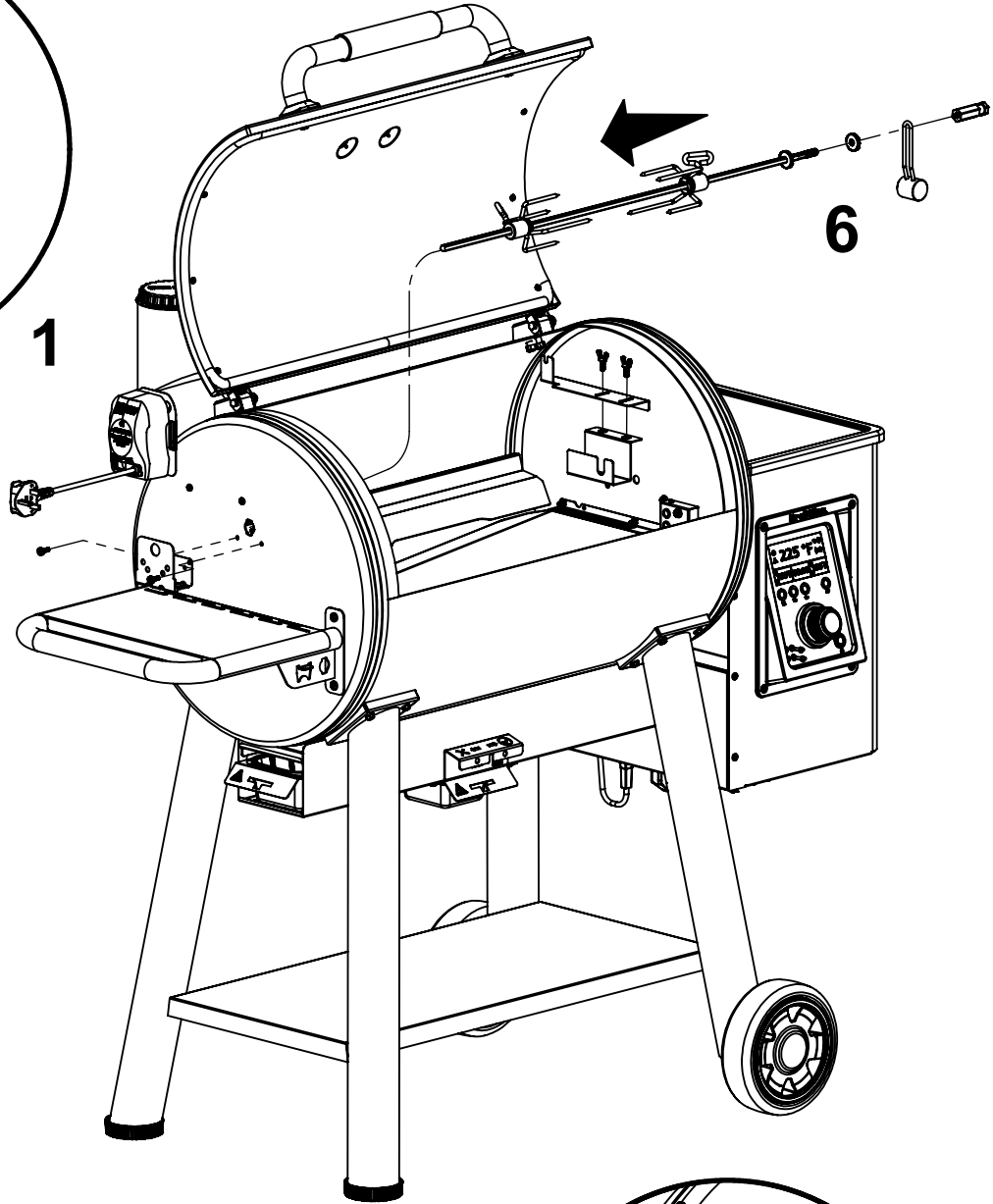
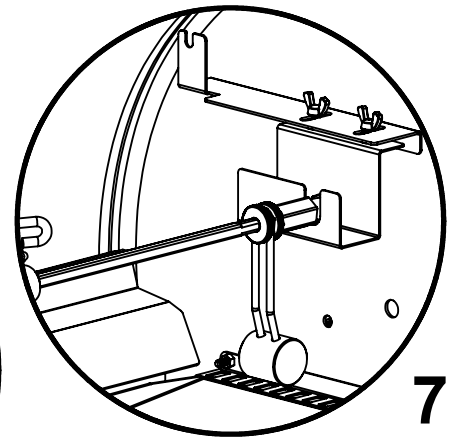
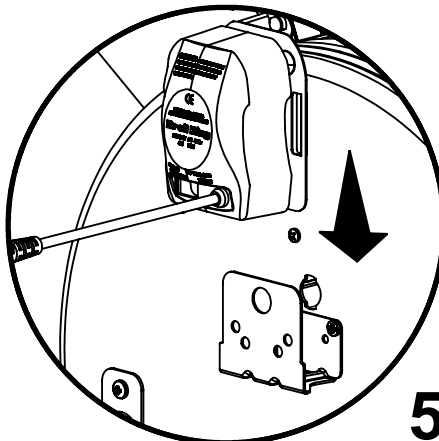
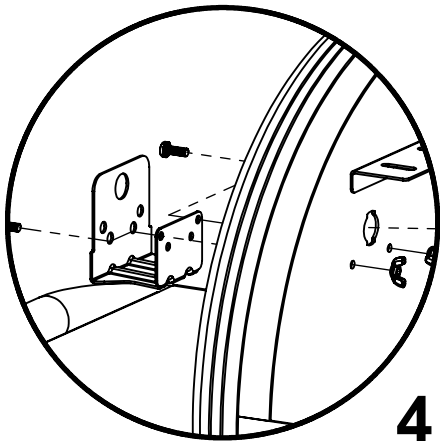
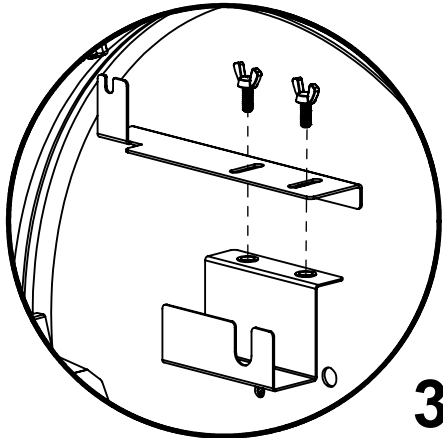
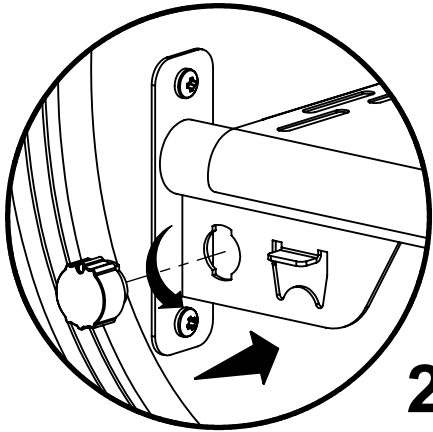
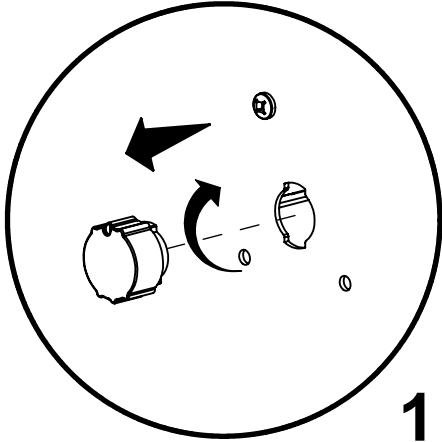
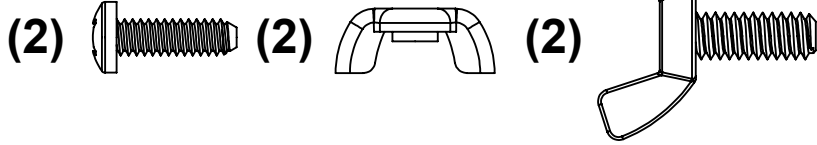

KEY#	ITEM#	DESCRIPTION (ENGLISH)	495055 495055EU	496055 496055EU	495055CH	496055CH	495055UK 495055GBC	496055UK 496055GBC
1	49302-13A	LID-WELDED ASSEMBLY-PELLET 625	-	1	-	1	-	1
	49305-13A	LID-WELDED ASSEMBLY-PELLET 500	1	-	1	-	1	-
2	44599-30BK	NAMEPLATE - PELLET	1	1	1	1	1	1
3	54009-94	HANDLE SEAT	2	2	2	2	2	2
4	24003-13A	HANDLE-LID ASSEMBLY	1	1	1	1	1	1
5	45304-90A	GASKET-LID-PELLET 625	-	1	-	1	-	1
	45306-90A	GASKET-LID-PELLET 500	1	-	1	-	1	-
6	49005-99	GRID-WARMING RACK-PELLET 625	-	1	-	1	-	1
	49004-99	GRID-WARMING RACK-PELLET 500	1	-	1	-	1	-
7	22005-281	CAST COOKING GRID	4	5	4	5	4	5
8	45305-25	GUIDE PLATE-PELLET 625	-	2	-	2	-	2
	45304-25	GUIDE PLATE-PELLET 500	2	-	2	-	2	-
9	45305-85A	HEAT SHIELD-PELLET 625	1	1	1	1	1	1
10	45305-78A	GREASE TRAY-WELDED ASSEMBLY	1	1	1	1	1	1
11	45305-77	GREASE TRAY-PELLET 625	-	1	-	1	-	1
	45304-77	GREASE TRAY-PELLET 500	1	-	1	-	1	-
12	45304-23	SHIELD-RADIATION-PELLET	1	1	1	1	1	1
13	49302-32A	CHIMNEY-WELDED ASSEMBLY	1	1	1	1	1	1
14	44599-40A	DAMPER CAP ASSEMBLY	1	1	1	1	1	1
15	46303-67A	DAMPER-BURNPOT	1	1	1	1	1	1
16	45304-11	SUPPORT-BURNPOT	1	1	1	1	1	1
17	45303-10A	BURNPOT-WELDED ASSEMBLY	1	1	1	1	1	1
18	66440-99	HOT ROD-PELLET(CE)	1	1	1	1	1	1
19	49302-00A	FIREBOX-WELDED ASSEMBLY-PELLET 625	-	1	-	1	-	1
	49305-00A	FIREBOX-WELDED ASSEMBLY-PELLET 500	1	-	1	-	1	-
20	65303-12	PROBE-PELLET(P1000)	1	1	1	1	1	1
21	45303-34	BRACKET-PROBE INNER	1	1	1	1	1	1
22	49303-14	PROBE BOX	1	-	1	-	1	-
23	45303-80	HANDLE-WELDED ASSEMBLY-PELLET	1	1	1	1	1	1
24	45305-84	BRACKET-ROTISSERIE	2	2	2	2	2	2
25	45303-61	SHELF-SIDE-PELLET	1	1	1	1	1	1
26	49302-26	CAP-ROTISSERIE	1	1	1	1	1	1
27	49302-23A	HINGE-ASSEMBLY	2	2	2	2	2	2
28	49303-16	BRACKET-WARMING RACK LH	1	1	1	1	1	1
29	49303-17	BRACKET-WARMING RACK RH	1	1	1	1	1	1
30	45305-74	BRACKET-GREASE TRAY	2	2	2	2	2	2
31	45305-79	GREASE TUBE	1	1	1	1	1	1
32	45303-04A	AUGER ENCLOSURE-WELDED ASSEMBLY-PELLET 625	-	1	-	1	-	1
	45306-04A	AUGER ENCLOSURE-WELDED ASSEMBLY-PELLET 500	1	-	1	-	1	-
33	45304-88	BASE-AGITATOR	1	1	1	1	1	1
34	45303-51A	AGITATOR-WELDED ASSEMBLY	1	1	1	1	1	1
35	49440-96	FAN-DC(12V)	1	1	1	1	1	1
36	49303-81A	SUPPOT-HOPPER-ASSEMBLY	1	1	1	1	1	1
37	49304-61	ASH TRAY	1	1	1	1	1	1
38	49303-53	BRACKET-ASH TRAY	2	2	2	2	2	2
39	45304-63A	COVER-GREASE TRAY-PELLET	1	1	1	1	1	1
40	50417	GREASE PAN-PELLET	3	3	3	3	3	3
41	49440-17	GREASE TRAY	1	1	1	1	1	1
42	49304-51	AUGER-PELLET 625	-	1	-	1	-	1
	49306-51	AUGER-PELLET 500	1	-	1	-	1	-
43	45306-53	COLLAR-AUGER MOTOR	1	1	1	1	1	1
44	45304-90	COLLAR-AUGER-PELLET	1	1	1	1	1	1
45	45303-76A	BRACKET-MOTOR	1	1	1	1	1	1
46	66440-91	AUGER MOTOR-PELLET(CE)	1	1	1	1	1	1
47	45304-28	BRACKET-WIRE-PELLET	1	1	1	1	1	1
48	45306-02-2	HINGE-HOPPER	8	8	8	8	8	8
49	49304-56A	FUEL DOOR-ASSEMBLY-PELLET	1	1	1	1	1	1
50	46625-92A	PANEL-HOPPER	1	1	1	1	1	1
51	66440-97	WIRE-POWER CORD(CE-UK)	-	-	-	-	1	1
	66441-97	WIRE-POWER CORD(CE-CH)	-	-	1	1	-	-
	66442-97	WIRE-POWER CORD(CE-EU)	1	1	-	-	-	-
52	66303-91	BLOCK-POWER CORD(CE)	1	1	1	1	1	1
53	49302-01A	LID-ASSEMBLY-HOPPER-PELLET	1	1	1	1	1	1
54	49303-26A	HOPPER-MESH LID ASSEMBLY-PELLET	1	1	1	1	1	1
55	49303-01A	HOPPER-WELDED ASSEMBLY	1	1	1	1	1	1
56	49440-86	SIDE DOOR-HOPPER 440	1	1	1	1	1	1

KEY#	ITEM#	DESCRIPTION (ENGLISH)	495055 495055EU	496055 496055EU	495055CH	496055CH	495055UK 495055GBC	496055UK 496055GBC
57	66603-89A	PCB CONTROLLER ASSEMBLY-PELLET 625(CE)	-	1	-	1	-	1
	66606-89A	PCB CONTROLLER ASSEMBLY-PELLET 500(CE)	1	-	1	-	1	-
58	22001-668C	CONTROL KNOB - SMALL	1	1	1	1	1	1
59	49301-6B	PROBE-TEMPERATURE B (PT1000)	1	1	1	1	1	1
60	45303-64	PROBE-TEMPERATURE (PT1000)	1	1	1	1	1	1
61	45303-45A	SINGAL RECEIVER	1	1	1	1	1	1
62	42302-30	LEG/WHEEL-WELDED ASSEMBLY(RR)	1	1	1	1	1	1
63	42302-40	LEG-WELDED ASSEMBLY(LR)	1	1	1	1	1	1
64	42302-20	LEG-WELDED ASSEMBLY(LF)	1	1	1	1	1	1
65	42302-10	LEG/WHEEL-WELDED ASSEMBLY(RF)	1	1	1	1	1	1
66	61302-41	BASE-PELLET 625	-	1	-	1	-	1
	61305-41	BASE-PELLET 500	1	-	1	-	1	-
67	41302-33	LEVELER-LEG	2	2	2	2	2	2
68	G01A0009	WHEEL	2	2	2	2	2	2
69	G01CP009	CAP-WHEEL	2	2	2	2	2	2
70	60745	STEEL GRID LIFTER	1	1	1	1	1	1
71	Y-11560S	SCREW 1/4-20X1.5"	5	5	5	5	5	5
72	Y-12859S	SCREW 1/4-20X1"	12	12	12	12	12	12
73	44304-72	PANEL-LID INNER 625	-	1	-	1	-	1
	44306-72	PANEL-LID INNER 500	1	-	1	-	1	-
74	Y-12865S	SCREW 1/4-20X0.5"	14	14	14	14	14	14
75	Y-29304S	SCREW #10-24X0.625"	10	10	10	10	10	10
76	49302-24	HINGE-LID	2	2	2	2	2	2
77	C01004	SCREW M4X6	3	3	3	3	3	3
78	Y-11805	NUT-HEX #10-24	10	10	10	10	10	10
79	60240-13	HINGE-LID	2	2	2	2	2	2
80	Y-15008S	NUT-LOCKING M8x1.25	6	6	6	6	6	6
81	63599-73C	SCREW-SHOULDER #10-24	2	2	2	2	2	2
82	C01015	SCREW-GROUND M5X16	1	1	1	1	1	1
83	G01CH038	NUT-LOCKING M8x1.25	2	2	2	2	2	2
84	Y-29304S	SCREW #10-24X0.625"	27	27	27	27	27	27
85	Y-29324	SCREW #10-24x1.5"	4	4	4	4	4	4
86	63599-78	SCREW-SHOULDER #10-24	2	2	2	2	2	2
87	C05010	SCREW M5X10	2	2	2	2	2	2
88	C01025	SCREW M5X35	4	4	4	4	4	4
89	C11005	SPRING WASHER φ5	1	1	1	1	1	1
90	Y-11698S	SCREW-BUTTERFLY 1/4"-20X0.625"	2	2	2	2	2	2
91	C01024	SCREW-TAPING ST4.2X9.5	2	2	2	2	2	2
92	C11050	THRUST WASHER φ5	1	1	1	1	1	1
93	C20005	NUT-HEX M5	1	1	1	1	1	1
94	Y-12859S	SCREW 1/4-20X1"	12	12	12	12	12	12
95	S15244	ROTISSERIE MOTOR(CE-UK)	-	-	-	-	1	1
	S15245	ROTISSERIE MOTOR(CE-CH)	-	-	1	1	-	-
	S15246	ROTISSERIE MOTOR(CE-EU)	1	1	-	-	-	-
96	57039-901	ROTISSERIE BRACKET	1	1	1	1	1	1
97	S35095	ROTISSERIE SCREW #10-24X0.625	2	2	2	2	2	2
98	S21061	WING NUT #10-24	2	2	2	2	2	2
99	S15763	SPIT ROD (24.8")	1	-	1	-	1	-
	S15256	SPIT ROD (31.0")	-	1	-	1	-	1
100	S15287	ROTISSERIE MEAT FORKS	2	2	2	2	2	2
101	S15299	COUNTER WEIGHT WASHER	1	1	1	1	1	1
102	S15270	ROTISSERIE COUNTER WEIGHT	1	1	1	1	1	1
103	S15761	ROTISSERIE COLLAR-PELLET	1	1	1	1	1	1
104	45303-18A	BRACKET-ROTISSERIE ASSEMBLY-PELLET	1	1	1	1	1	1
105	Y-11698S	SCREW-BUTTERFLY 1/4"-20X0.625"	2	2	2	2	2	2
106	Y-12885S	SCREW 1/4-20x0.375"	4	4	4	4	4	4
107	C11007	SPRING WASHER φ7	4	4	4	4	4	4
108	C01005	SCREW M5X10	8	8	8	8	8	8
109	46440-66	BUSING-PROBE	2	2	2	2	2	2
110	66303-93	BLOCK-MEAT PROBE	2	2	2	2	2	2
111	66303-92	CLIP-POWER CORD-BIG	1	1	1	1	1	1
112	66303-38A	GROUND PLATE-ASSEMBLY(CE)	1	1	1	1	1	1
113	66303-87	SOCKET-POWER CORD(CE)	1	1	1	1	1	1
114	66303-88	CLIP-POWER CORD(CE)	1	1	1	1	1	1
115	C01003	SCREW M3X10	4	4	4	4	4	4
	496051-HP	HARDWARE PACK	1	1	1	1	1	1

